

# ROTARY PISTON VACUUM PUMPS

## Heavy Vapor Load

### RP-35DD-XP & RP-50DD-XP



**US VACUUM** offers our RP series of Rotary Piston vacuum pumps that are modified for use in heavy duty INDUSTRIAL applications where condensable/flammable gases or vapors are present. Designed for production duty applications where machine downtime is not an option.

These units have been EXCLUSIVELY DESIGNED for use in heavy water vapor or solvent vapor applications where a cost effective alternative to expensive dry pumping technology is desired. Large oil supply for dilution of contaminate vapors, direct drive gearbox design with standard explosion-proof motor and solenoid valve, lubrication system & heavy duty Grid type drive coupling. Combined with our SLR (Synthetic Low Reactivity) pump fluid (Standard) there is not a more durable oil lubricated vacuum pump on the market today.

Low pump rpm (424-612 rpm) and generous oil supply insures minimal wear and long term durability. Typical applications include transformer drying & degassing, lube oil purification, polymer processing, resin infusion, adhesive-sealant & coatings manufacturing, vacuum ovens & chemical mixing/blending.

### FEATURES

- Air Cooled
- Industrial Duty
- Vacuum 0.010mm
- Low operating temperature
- Full Pumping Speed to 1 Torr
- Oversized Exhaust Filtration



PUMPING SPEED CAPACITY CURVES  
60Hz

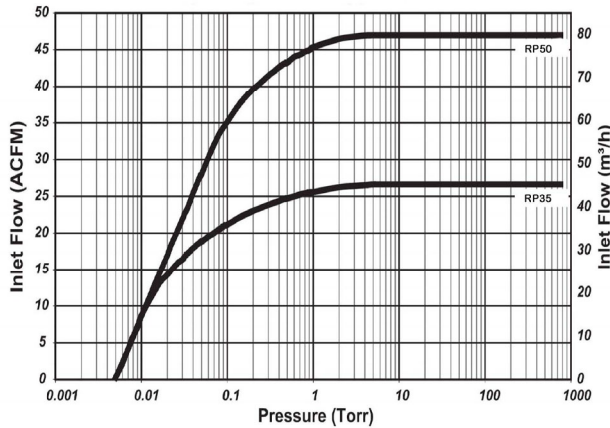

## SPECIFICATIONS

Pump Model		RP-35	RP-50
Displacement	CFM	35	52
Ultimate Vacuum	Torr	0.010	0.010
Motor	Hp	2	3
Pump Speed	RPM	424	612
Oil Capacity	Gal	4	4
Inlet connection	in.	2"	2"
Exhaust connection	in.	2"	2"
Pump Weight	Lbs.	485	495

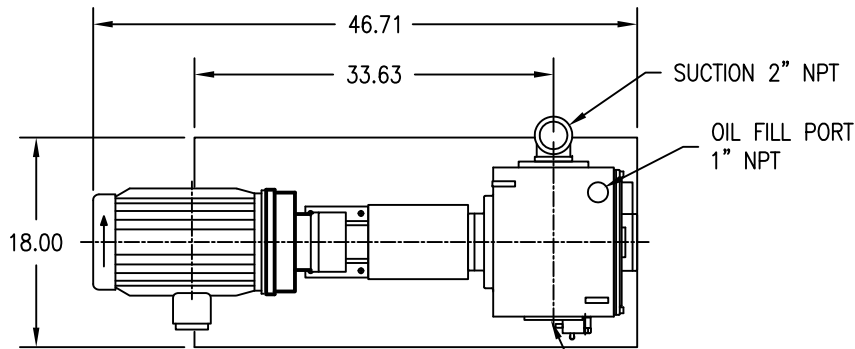

**PLAN**

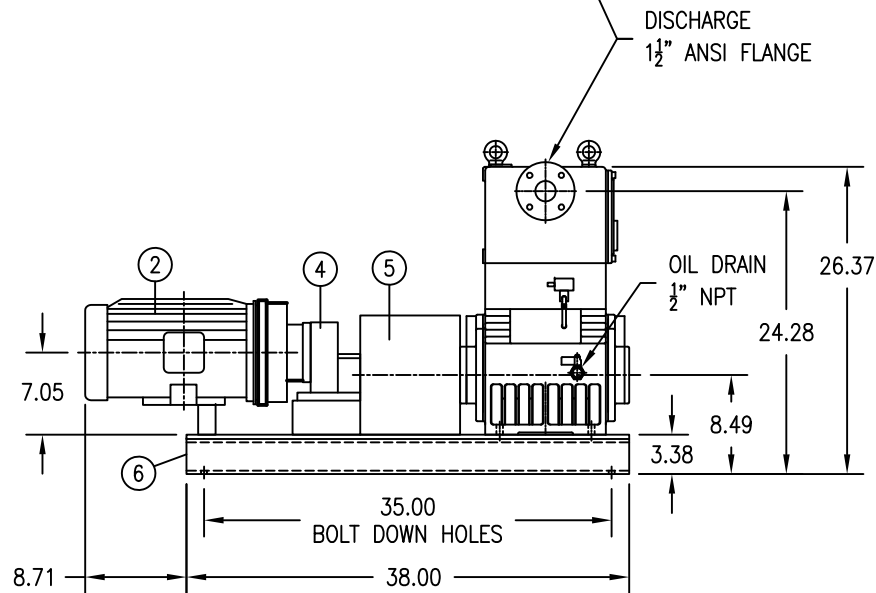

**ELEVATION**

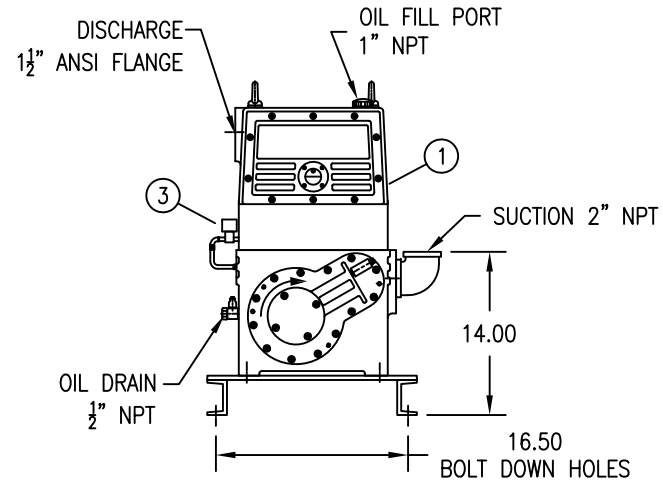

**END VIEW**

NO.	QTY	DESCRIPTION
1	1	VACUUM PUMP MODEL RP50C-WS
2	1	ELECTRIC MOTOR: 3hp, 230-460v, 1750rpm
3	1	SOLENOID VALVE, 460v, N.C.
4	1	GEARBOX, DODGE HB381
5	1	COUPLING, DODGE E5 & GUARD
6	1	FRAME, FABRICATED STEEL, 3"

**NOTES:**

1. ALL STANDARD UNIT PIPING SHALL BE SCH/40 ASTM A-53 TYPE F C/W 150# ASTM A-197 MALLEABLE IRON THREADED FITTINGS.
2. CUSTOMER IS RESPONSIBLE FOR PROPER LIFTING EQUIPMENT FOR LIFTING SKID.
3. ANCHOR BOLTS ARE NOT FURNISHED WITH UNIT.
4. MOTOR: 3Hp, 1750RPM, 230-460V, 60hz, 3-ph
5. PUMP: 44CFM DISPLACEMENT, MAX VAC 0.050mmHg (Abs).
6. WEIGHTS: OPERATING = 455lbs, SHIPPING = 530lbs.
7. PUMP RPM = 532

DIMENSIONS ARE IN INCHES [mm]  
WEIGHT IN LBS [kg]  
THIRD ANGLE  
PROJECTION

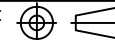

REV	DESCRIPTION	JCM	PD	PD	DATE
0	GENERAL REVISION	JCM	PD	PD	26-FEB-18
DWN	JCM 26-FEB-18	DWN	CK	APP	DATE
CK	PD 26-FEB-18	THIS DRAWING AND ALL INFORMATION SHOWN HEREON ARE THE EXCLUSIVE PROPERTY OF US VACUUM PUMPS AND ARE SUBMITTED ON A CONFIDENTIAL BASIS ONLY. THE RECIPIENT AGREES NOT TO REPRODUCE THE DISCLOSURE OF THE DRAWING AND THAT NO SHOWN HEREON WILL BE MADE TO THE THIRD PARTY WITHOUT PRIOR WRITTEN CONSENT OF US VACUUM.			
APP	PD 26-FEB-18				
SCALE NTS		<b>CERTIFIED DRAWING</b> <b>US VACUUM PUMPS, LLC</b> P.O. BOX 909 CANTON, TEXAS 75103 PH: 888-416-7466 / FAX: 877-416-7599			
RP-50C WS VACUUM PUMP SYSTEM SKID MOUNTED					
DWG. NO. US-GA-RP50C-DD-FRM-10					REV 0