

ROTARY PISTON Vacuum Pump



RP-150H™ & RP-300H™

US VACUUM RP series of Rotary Piston vacuum pumps are heavy duty INDUSTRIAL GRADE units capable of producing an ultimate vacuum of 0.010 mmHg (abs). The pump is designed for use in demanding industrial applications where high vacuum, high flow and heavy duty construction are required.

The RP-150H/RP300H are HEAVY DUTY robust vacuum pumps designed for the most demanding pumping applications where higher vacuum is required while also being tasked with handling contaminating process gases and vapors.

Low operating RPM, single piston design combined with generous oil capacity provides durability and uptime when pumping compromised gas streams. Excellent choice for vacuum heat treating, coating, transformer drying,

FEATURES

- Industrial Duty design
- Low operating RPM
- Large oil capacity
- Ultimate vacuum to 0.010 Torr
- Robust and durable for long life

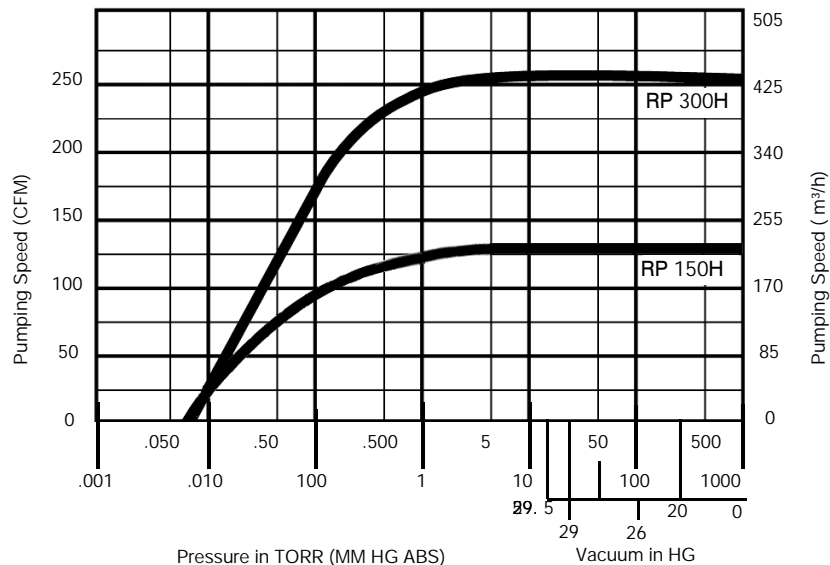

Pump Model		RP-150H	RP-300H
Displacement	CFM	150	300
Ultimate Vacuum	Torr	0.010 (10 Microns)	0.010 (10 Microns)
Motor	Hp	7.5	15
Pump Speed	RPM	500	490
Oil Capacity	Gal	4	12
Inlet connection	Inches	3" ANSI	4" ANSI
Discharge connection	Inches	2" ANSI	3" ANSI
Noise Level	dBa	71	72
Cooling Water	gpm	1	2
Pump Weight	Lbs.	950	1750

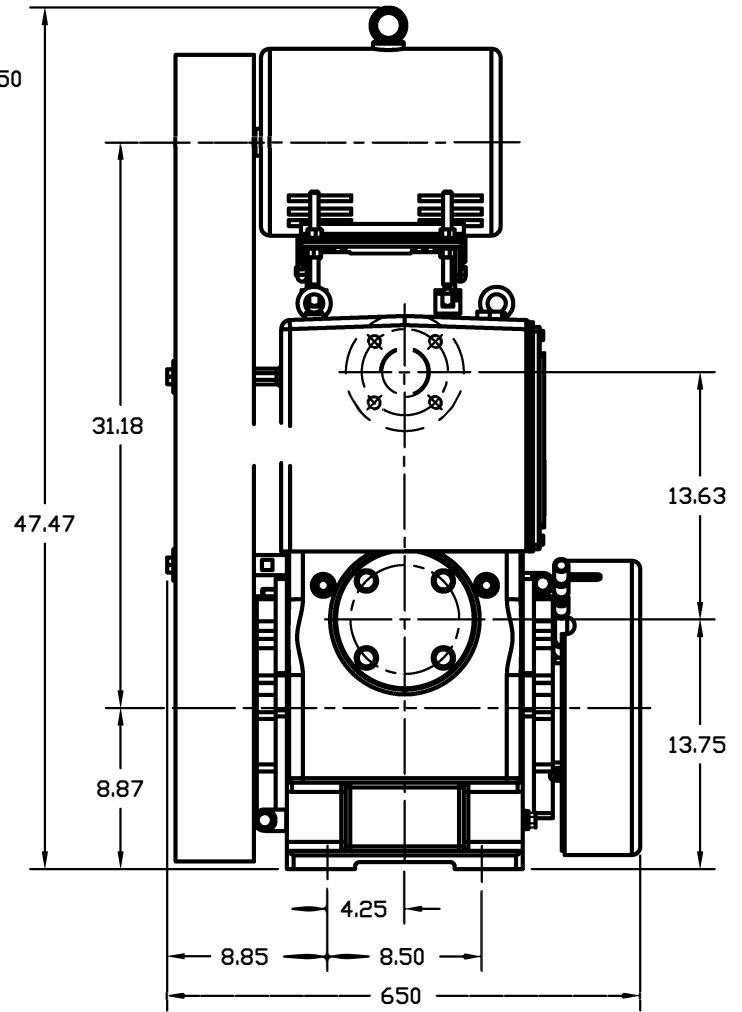
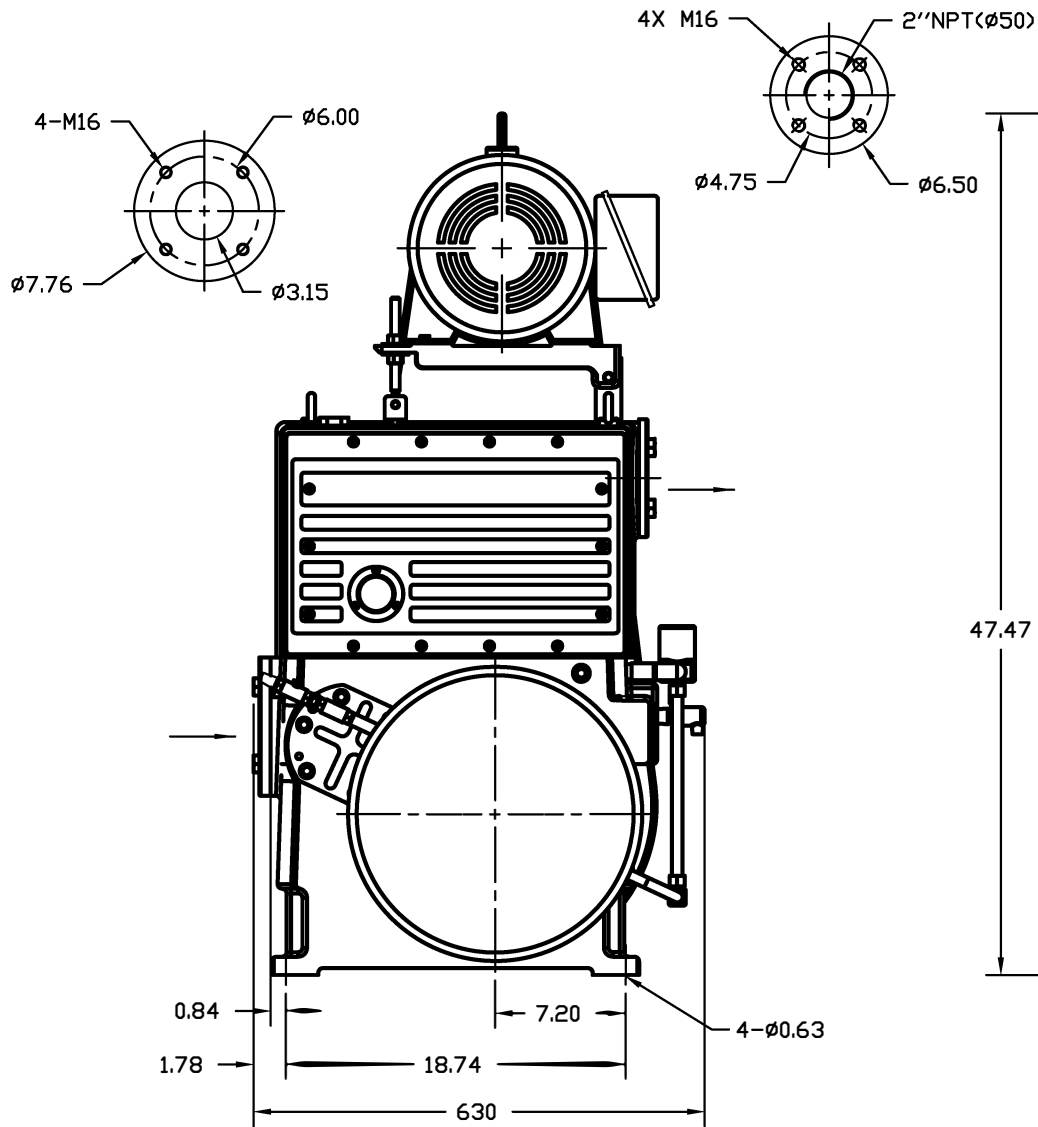

0	INITIAL RELEASE			JCM	PD	PD	10 -MAY 18
REV	DESCRIPTION			DWN	CK	APP	DATE
DWN	JCM	10 -MAY 18	<small>THIS DRAWING AND ALL INFORMATION SHOWN HEREON ARE THE EXCLUSIVE PROPERTY OF US VACUUM PUMPS, AND ARE SUBMITTED IN A CONFIDENTIAL MANNER. THE RECIPIENT AGREES TO REPRODUCE THE INFORMATION ONLY TO RETURN IT UPON REQUEST AND THAT NO THIRD PARTY WITHOUT PRIOR WRITTEN CONSENT OF USVP.</small>	CERTIFIED DRAWING			
CK	PD	10 -MAY -18		US VACUUM PUMPS, LLC			
APP	PD	10 -MAY -18		P.O. BOX 909 CANTON, TEXAS 75103 PH: 888-416-7466 / FAX: 877-416-7599			
SCALE	NTS						
RP-150H ROTARY PISTON VACUUM PUMP							
DWG. NO.						REV	
RP150H.M4A1.460						O	

DIMENSIONS ARE IN INCHES [mm]
WEIGHT IN LBS [kg]

FIRST ANGLE PROJECTION

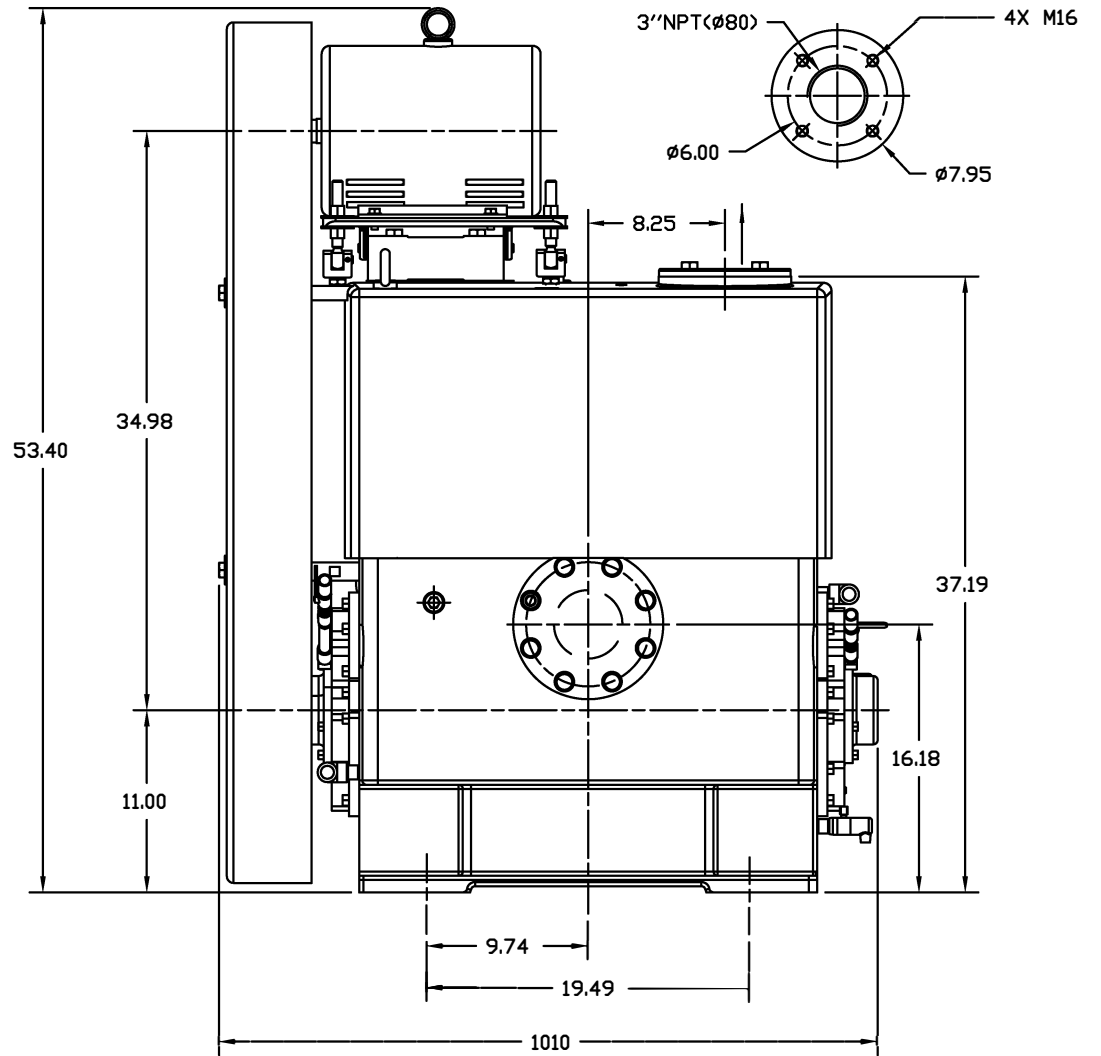
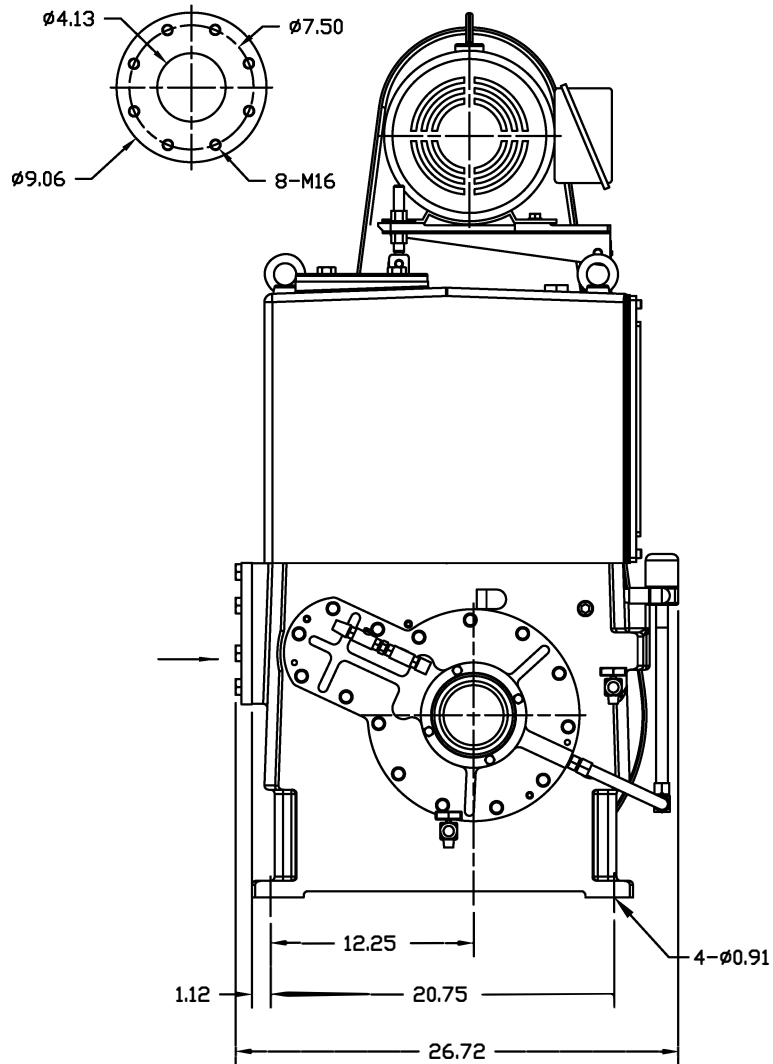

DIMENSIONS ARE IN INCHES [mm]
 WEIGHT IN LBS [kg]
 FIRST ANGLE PROJECTION

0	INITIAL RELEASE			JCM	PD	PD	10-MAY-18
REV	DESCRIPTION			DWN	CK	APP	DATE
DWN	JCM	10-MAY-18	THIS DRAWING AND ALL INFORMATION SHOWN HEREON ARE THE EXCLUSIVE PROPERTY OF DOWDY VACUUM PUMPS AND ARE SUBMITTED ON A CONFIDENTIAL BASIS ONLY. THE RECIPIENT AGREES NOT TO DISCLOSE OR THE DISCLOSURE OF THE DRAWING OR THE INFORMATION DRAWING TO RETURN BY UPON REQUEST AND THAT NO OTHER PERSON WILL BE MADE TO THE PRODUCT WITHOUT PRIOR WRITTEN CONSENT OF DOWDY.	CERTIFIED DRAWING			
CK	PD	10-MAY-18					
APP	PD	10-MAY-18					
SCALE	NTS						
RP-300H ROTARY PISTON VACUUM PUMP				US VACUUM PUMPS, LLC P.O. BOX 909 CANTON, TEXAS 75103 PH: 888-416-7466 / FAX: 877-416-7599			
				DWG. NO. RP300H.M4A1.460			REV 0